

Fittings

- Shelf Stud **x 5**
- Turnfaster Fitting **x 2**
- Adjustable Leg **x 5**
- Leg Boss **x 5**
- Springfit Dowel **x 2**
- Centre Mullion Bracket **x 4**
- Hinge Mounting Plate **x 2**
- Plinth Clip **x 2**
- Standard Hinge **x 2**
- Circular Leg Clip **x 2**
- N 15mm Screws x 36**
- O 30mm Screws x 9**

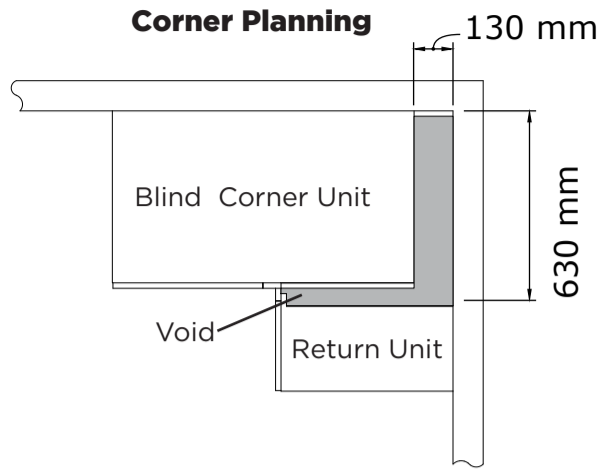

- (A)** Base End Panel
- (B)** Top/Bottom Panel
- (C)** Back Panel
- (D)** Shelf
- (E)** Centre Mullion
- (F)** Corner Post
- (G)** Blanking Panel
- (H)** Corner Post
- (J)** Corner Spacing Panel
- (K)** Door

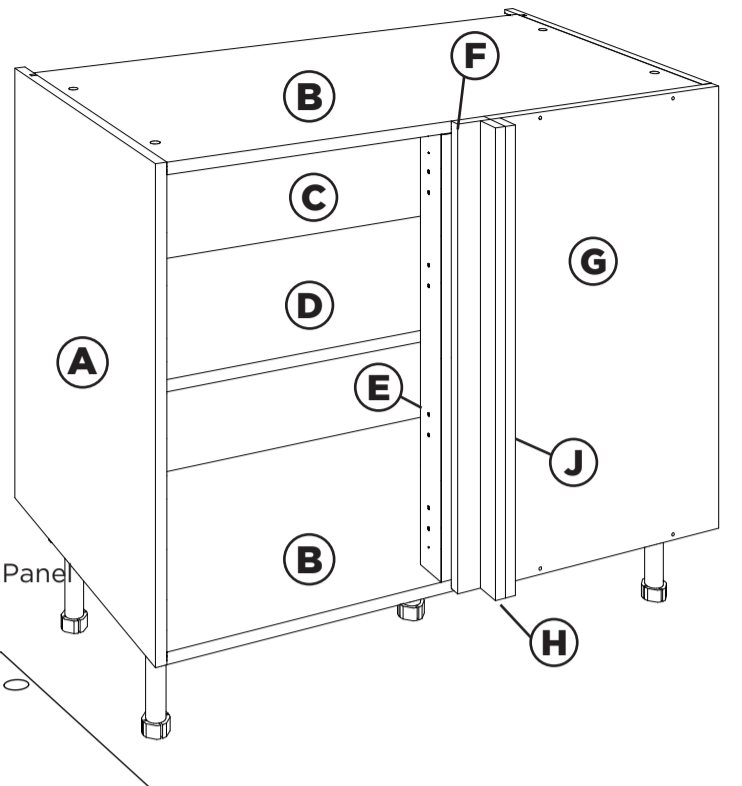

Assembly

1 Carefully align front edges

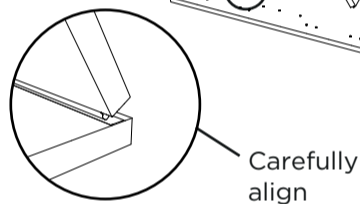

We recommend using PVA glue for an additional bond - simply run a bead of glue along each joint line during assembly

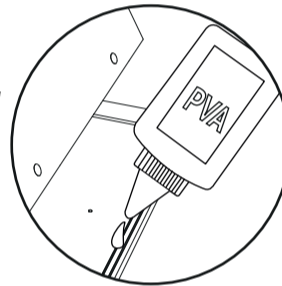

2

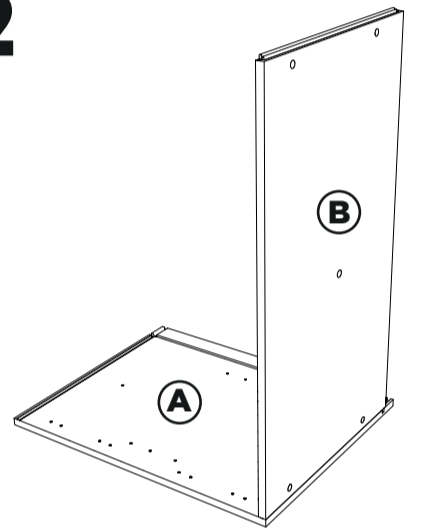

3

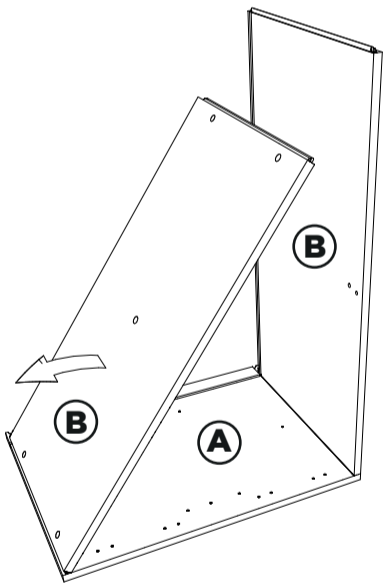

4

Slide back panel into place

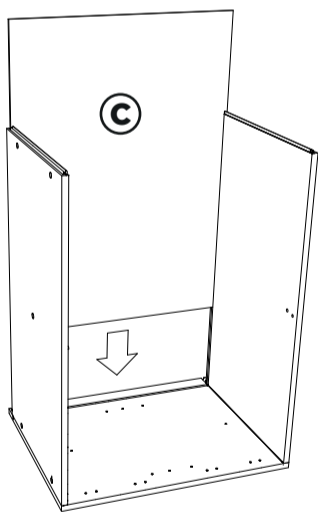

5

Press end panel A into top-bottom panels B and gently tap with a mallet

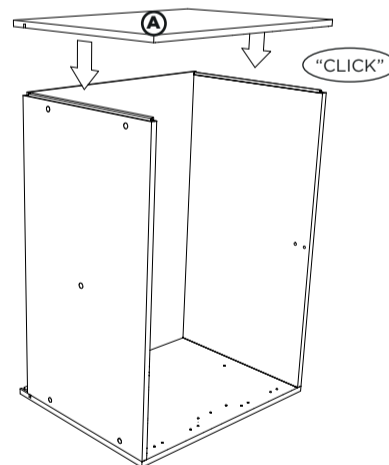

6

Insert shelf studs

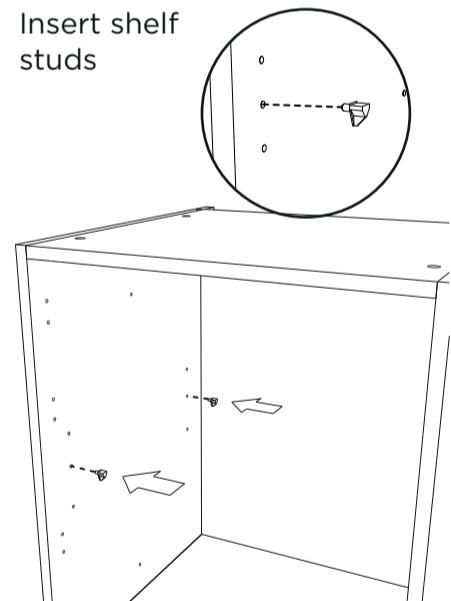

7

Gently tap leg boss into place

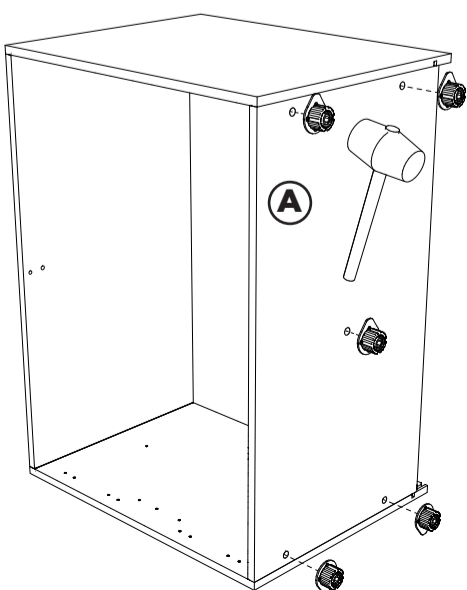

8

Screw leg boss in place

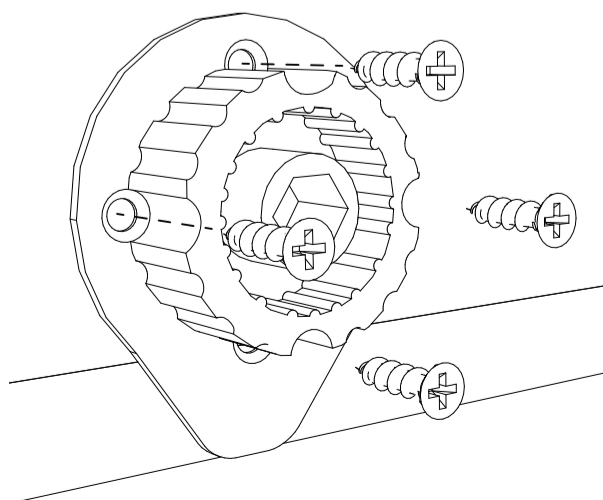

9

Insert adjustable legs into leg boss

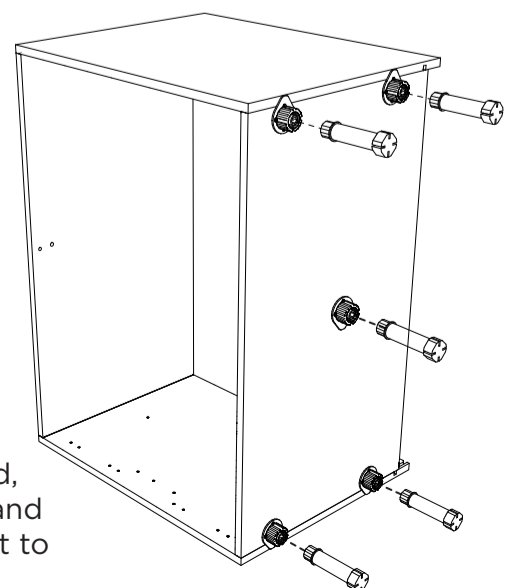

Once assembled, measure and adjust feet to 150mm

10 Insert turnfastener fittings to inside base panel B

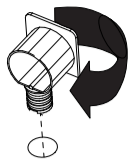

Rotate to lock into place

B

11

Press springfit dowels into top and bottom of centre mullion

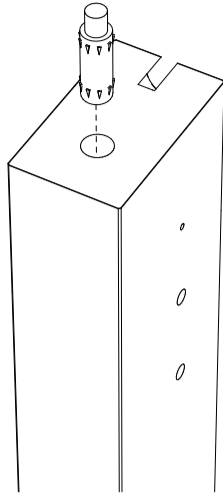

12

Once dowels are pressed in, slide centre mullion into place

Step 1

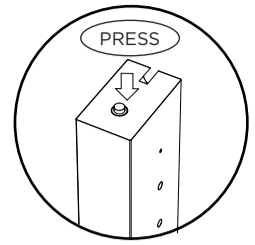

Step 2

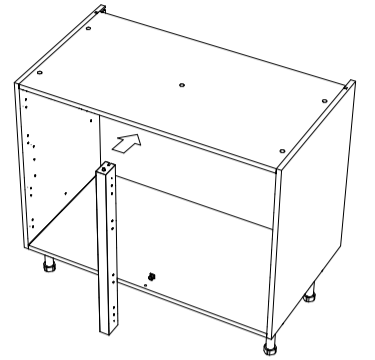

13

Attach panel G to cabinet frame - carefully align with edges of cabinet at top, bottom and side.

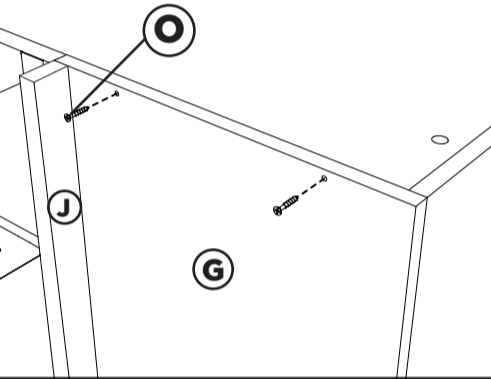

14

Assemble corner post F to corner post H using 30mm screws

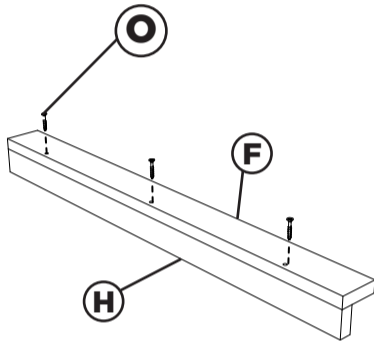

15

Tip 'clamp corner posts in position'

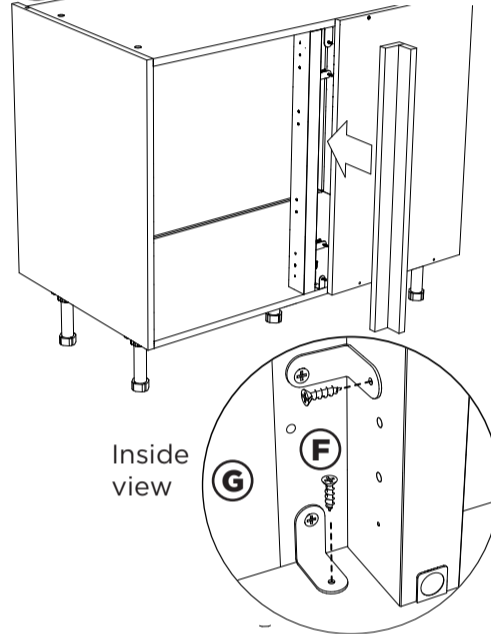

16

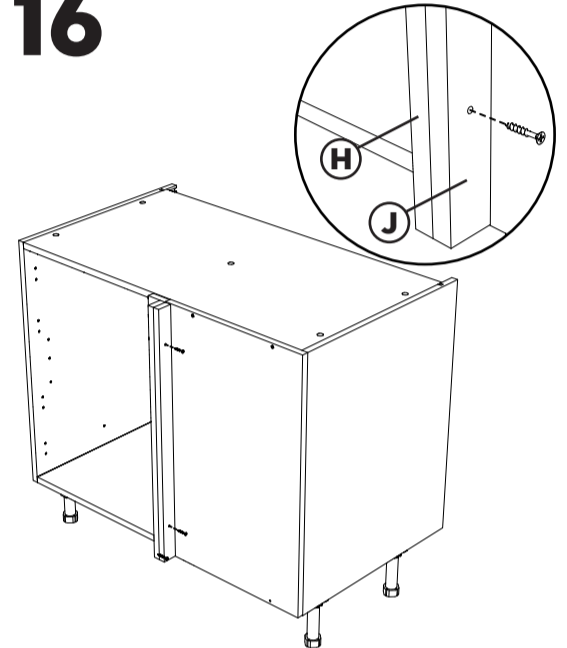

17

Insert shelf studs and slide shelf D into position

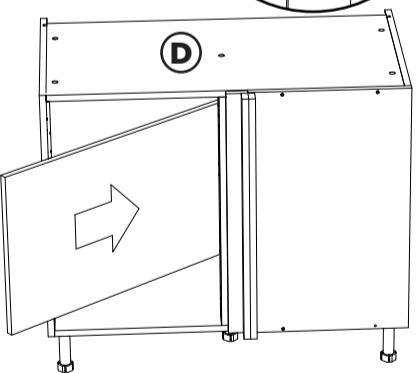
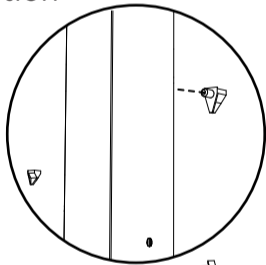

18

Attach plinth clip to plinth

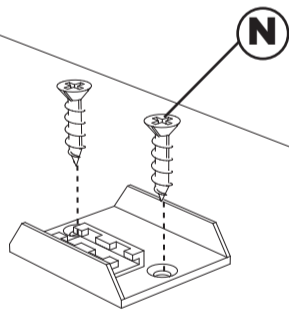

19

Slide circular leg clip into plate

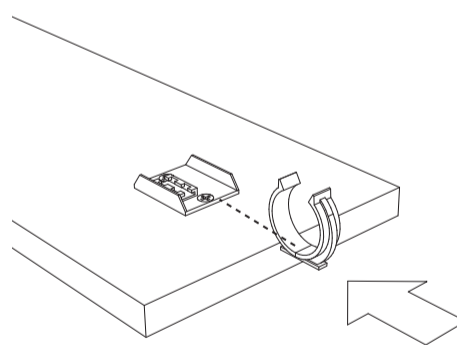

20

Fix plinth into place

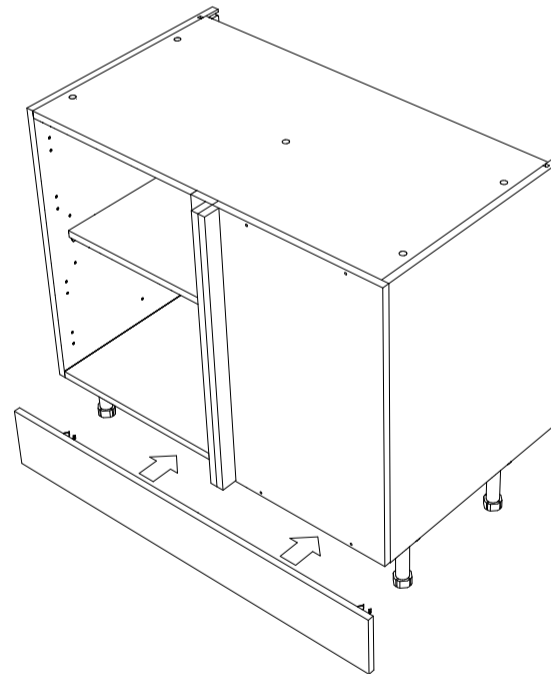

21

Attach hinge mounting plate to centre mullion

Ensure the front edge faces forward as shown

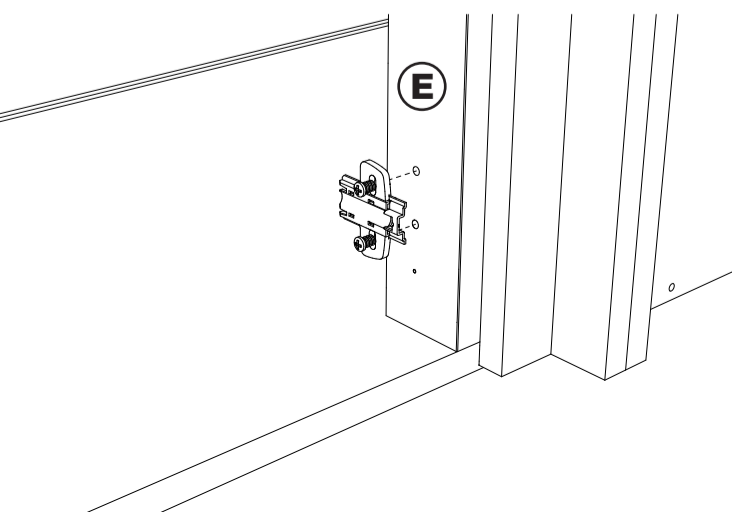

22

Ensure the hinge arm is at 90 degrees to the door before fixing in position with 15mm screws as shown

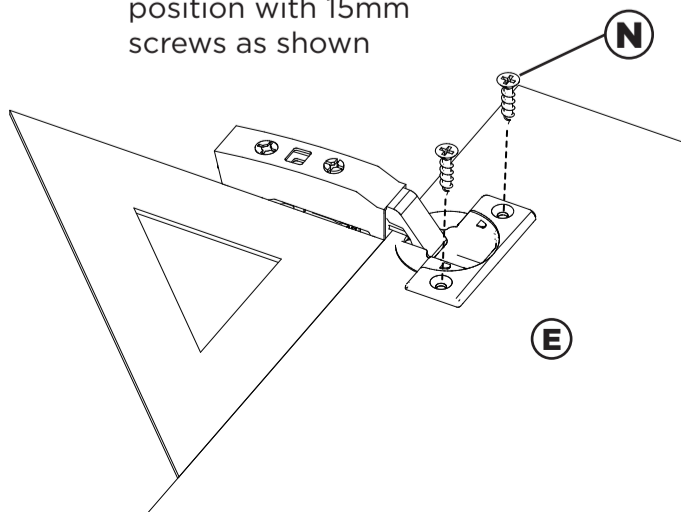

23

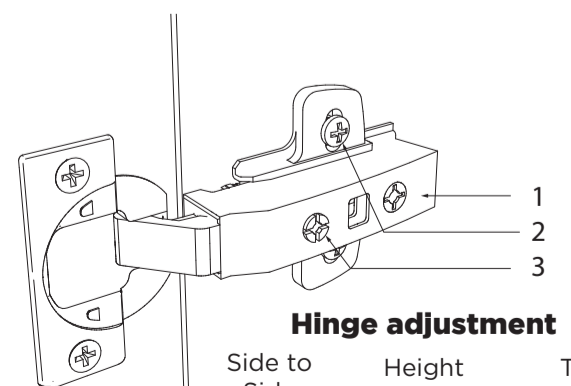

Hinge adjustment

Side to Side Height Tilt

